

SQ-R+

Contact-free Discharge Measurement System

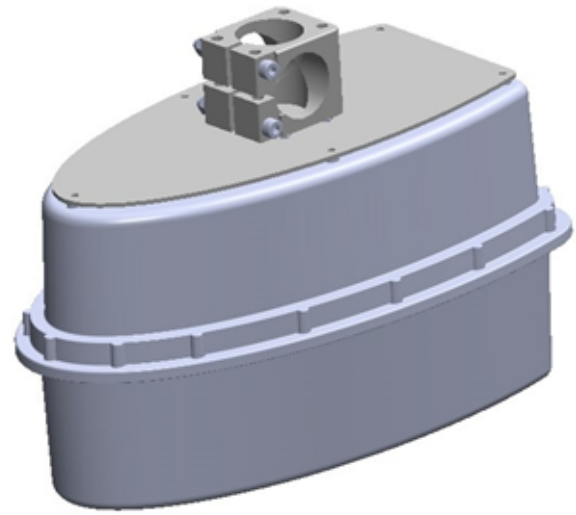

The exact and real time knowledge of water discharge is of central importance for the operation of waste water treatment facilities, cost allocation in sewage networks and management of communal and industrial water resources.

The SQ-R+ sensor is a continuous measurement device for the contact-free determination of the water discharge of open or closed canals. It combines two sensors in one system. The first determines the water level by measuring the transit time of a radar signal, the second simultaneously measures the flow velocity of the water surface by means of the Doppler frequency shift. Following each measurement, the sensor applies an advanced hydraulic model from Sommer Messtechnik to compute the mean velocity, which in turn is used to calculate the water discharge.

Due to the contact-free measurement method the SQ-R+ can be installed on extension arms or cable ways without costly structural measures under or inside the water or sewage treatment canal. This also has the advantage that the sensor is located outside the danger area of floods and that it requires virtually no maintenance over many years.



FEATURES

- Contact-free radar method prevents soiling and damage, no sensor maintenance
- Automatic discharge calculation based on hydraulic model with multiple dyn. k-factors.
- Sensor self check with status and error output.
- AI-based machine learning for compensation of environmental influences and early detection of errors.
- 3-point velocity calibration certificate.
- Advanced velocity diagnostics with spectrum display
- Discharge calculation inside the SQ-R+.
- Water level and velocity sensor combined in one weather and vandalism proof housing.
- Sommer Messtechnik ANR: advanced noise reduction system

Versions

Art	Version
21599	SQ-R non-contact flowmeter for sewage and wastewater flow monitoring, with radar level and velocity sensors

Scope of delivery

Qty	Art	Item
1	-	SQ-R+ in the required version
1	-	Manual and SQ-Commander Software on USB stick

Accessories

Art	Accessory
20789	MAIN sensor cable SQ/USH-9, 10 m
20791	MAIN sensor cable SQ/USH-9, 20 m
-	MAIN sensor cable for SQ-R+ up to 60 m available on request
19294	USB to RS485 embedded converter cable, 1.8 m
22524	Universal extension box for cable extension
-	Radar velocity verifier

Specifications

Physical and environmental	
Power supply	9...30 VDC; Reverse voltage protection, overvoltage protection
Power consumption at 12 VDC	1.5 Ah per day Peak current drain 91 mA Inrush current <200 mA (for a measurement interval of 60 s)
Outputs	RS-485 ASCII or Modbus RTU SDI-12 Analog output 4...20 mA (14 bit, max. load 250 Ω) Digital output (low: 0 V, high: Vsupply, max. 1.5 A)
Operating temperature	-40...85 °C (-40...185 °F)
Storage temperature	-40...85 °C (-40...185 °F)
Relative humidity	0...100 %
Protection rating	IP 68
Lightning protection	Integrated protection against indirect lightning with a discharge capacity of 0,6 kW Ppp
Housing material	Zytel 103HSL NC010, resistant to aggressive substances typically found in sewage channels
Mounting bracket	Mounting cube for Ø30 mm pipe
Size L x W x H	272 x 152.2 x 185.5 mm (10.71 x 5.99 x 7.30 in), including mounting cube
Weight	1.55 kg (3.42 lb)

Velocity	
Detectable measurement range	0.08...16 m/s practical range (depending on surface water waves) 0.01...20 m/s technical range
Accuracy	± 0.01 m/s (certified by METAS)
Resolution	1 mm/s
Direction recognition	+/-
Measurement duration	5...240 s
Measurement interval	8 s...5 h
Measurement frequency	24 GHz (K-Band)
Radar opening angle	12°
Distance to water surface	0.05...130 m (0.16...426.51 ft)
Noise reduction	Sommer Messtechnik ANR (advanced noise reduction) based on velocity spectrum analysis

Automatic vertical angle compensation	
Vertical inclination	Measured internally
Accuracy	± 1 °
Resolution	± 0.1 °

Water level	
Measurement range (distance between level sensor and water surface)	0.05...8 m (0.16...26.25 ft)
Accuracy	≤ 2 mm
W-band (80 GHz technology)	W-band (80 GHz)
Opening angle	8 °

Features	
Self check	Internal self check with code output for each measurement
AI Machine learning	Internal Machine learning for velocity and discharge, outputted with each measurement.
Hydraulic model	Dynamically and automatically calculated k-factors for discharge calculation
Data quality	Internal measurement quality value output with each measurement